

## Instruction Manual

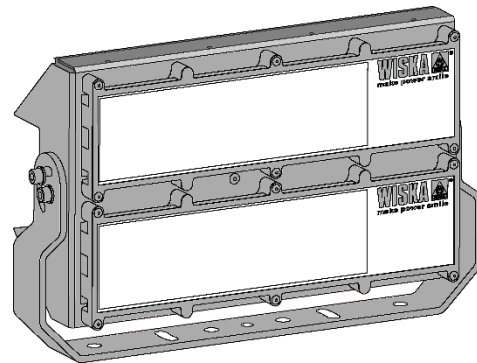
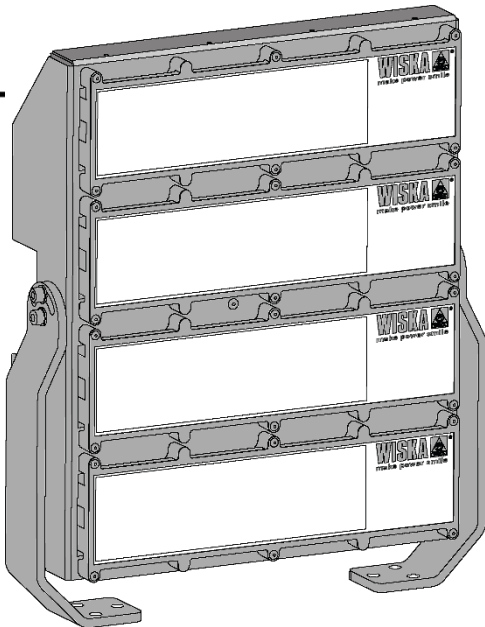

### Floodlight 5000

5000 1x40 / 5000 2x40 / 5000 3x40 / 5000 4x40

Keep the instruction manual always handy.

## Table of contents

1.	INTRODUCTORY REMARKS	3
2.	SAFETY INSTRUCTIONS	3
3.	DESCRIPTION AND INTENDED USE	5
4.	OPERATION	6
5.	MALFUNCTIONS DURING OPERATION	6
6.	CLEANING	6
7.	REGULAR REVIEW	7
8.	DISPOSAL AND DECOMMISSIONING	7
9.	TRANSPORT AND STORAGE	8
10.	MOUNTING AND ELECTRICAL CONNECTION	8
11.	COMMISSIONING	11
12.	MAINTENANCE AND REPAIR	12
13.	TECHNICAL DATA	16
14.	ACCESSORIES/SPARE PARTS	20
15.	DECLARATION OF CONFORMITY/CERTIFICATE	21

## 1. Introductory remarks

These operating instructions are intended for the operator, his personnel, and the installer. The instructions help correctly install Floodlight 5000 and use it safely in accordance with its intended purpose.







These instructions contain important information on the installation and operation of the floodlight. By following the given steps, hazards are avoided, repair costs and downtimes are reduced, and reliability and service life are increased.

Read the operating instructions carefully and attentively! WISKA Hoppmann GmbH is not liable for any damages or malfunctions resulting from the non-observance of these operating instructions.

## 2. Safety instructions

The operator bears the responsibility to use the product as described in the intended use.

A warning indicates dangerous situations to be avoided, followed by an explanation of the situation. The symbols and safety instructions used are as follows:

Icon	Signal word	Meaning
	<b>DANGER</b>	Probable result: Immediate death or serious injury
	<b>WARNING</b>	Possible result: death or serious injury
	<b>CAUTION</b>	Possible result: Slight to moderate injury to persons
	<b>ATTENTION</b>	Possible consequences: Material damage and malfunctions
	Electrician	Installation and repairs may only be carried out by a qualified electrician / electrical skilled person
	Electrical voltage	Injury due to open live parts and components
	Unlocking	Switch off the power before starting work and secure it against being switched on again

### 2.1 General safety instructions



Installation, commissioning, and maintenance should only be carried out by a qualified electrician.

Use Floodlight 5000 based on its IP protection class; otherwise, it may get damaged.

Avoid dropping or jolting the floodlight, as it could get damaged.

The tightening torques specified by the manufacturer must be observed.

Allow the LED module to cool for at least five minutes before replacing it.



**WARNING:** The Floodlight 5000 should only be opened or repaired by an authorized electrician.



**CAUTION:** Switch off Floodlight 5000 and disconnect it from the power source immediately if smoke, sparks, or fumes are emitted, or an unusual odor is detected.

## 2.2 Electrical voltage

Read this manual carefully. If applicable, also consider the operating instructions of other manufacturers.

Install Floodlight 5000 as described in this manual.

**ATTENTION:** Electrical connections and connection cables must comply with all relevant regulations.

Observe the safety regulations for electricians: Before starting any installation or maintenance work, disconnect the power supply, secure it from being switched on again, check that no voltage is present, earth and short-circuit and cover adjacent live parts.

**⚠ WARNING:** Floodlights must not be installed outdoors in rainy weather due to the danger of an electric shock.

**⚠ CAUTION:** Observe the load limits of extension cables and sockets to avoid the risk of fire or an electric shock.

**⚠ WARNING:** Never repair damaged power cables! This poses a danger to life. Disconnect the Floodlight from the mains and have it repaired.

All cables and accessories must be professionally installed to function reliably.

Consider the national and local installation requirements and classification rules. In some countries, lighting may only be installed by registered installers.

Clamping screws in electrical connections must be tightened as specified by the manufacturer.

Observe the symbols for connecting the cables in accordance with national directives:

N = Neutral L = Phase  = Earth LS = Live, switched.

## 2.3 These instructions apply to the following versions:

Floodlights 5000 1x40, 5000 2x40, 5000 3x40, 5000 4x40, either powered by AC mains or 24V DC, with and without a protective grid as well as narrow, normal, or wide beam versions.

## 2.4 Change history

Version	Revision date
1.0	02/2023

## 2.5 Original instructions

The German version of this document is the original manual.

### 3. Description and intended use

The Floodlight 5000 is used to illuminate surfaces in and on ships and is certified by DNV. The Floodlight 5000 is available in different versions, with one to four modules mounted on a support frame. It consists of a stainless steel support frame, LED module(s) in a plastic housing, a stainless steel mounting bracket, and a connection box, and the 5000 1x40 version comes with a cable. Optional protective grids are available for the front glass panes. The power supply is 230V AC. The floodlight with one module is alternatively available as a 24V DC variant.

The Floodlight 5000 is approved for outdoor use and meets the degrees of protection mentioned below:

- 1 module: IP66/68
- 2–4 modules: IP66/67.

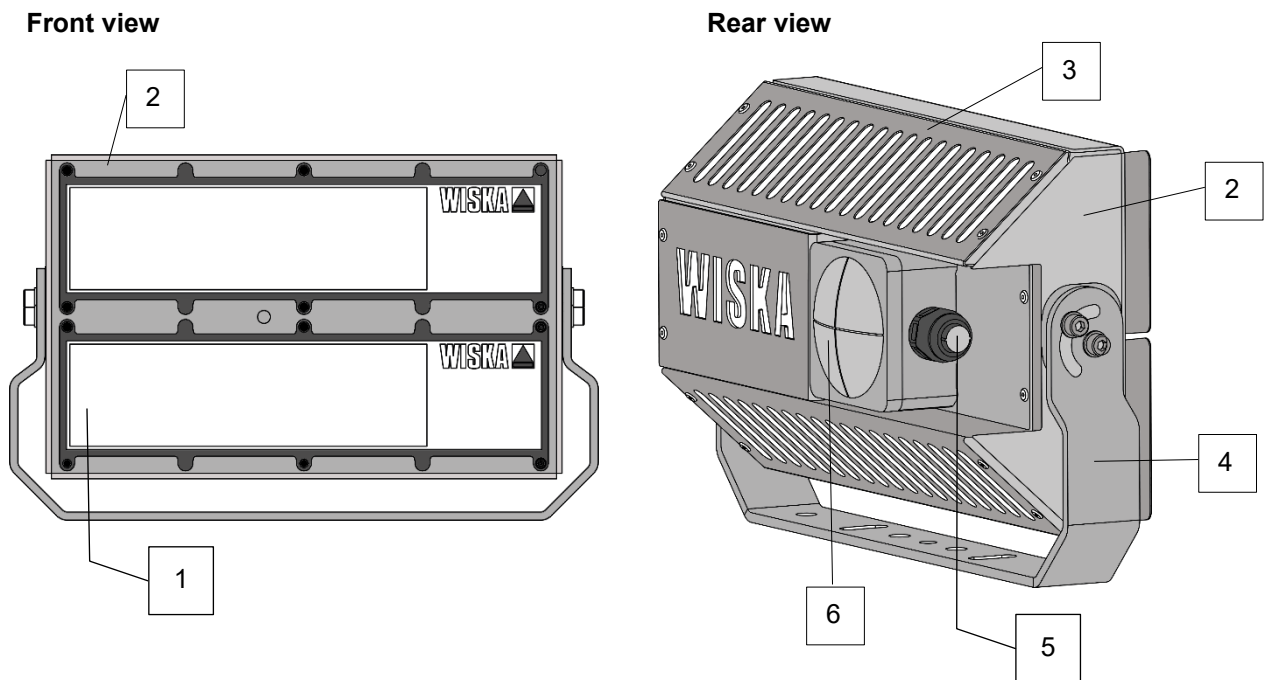

Illustration 1 - Overview Floodlight 5000 2x40

Pos.	Designation
1	LED module
2	Case
3	Cover
4	Mounting bracket
5	Cable gland
6	Terminal box

Floodlight 5000 is designed to illuminate surfaces on ships. Its usage is forbidden in the following scenarios:

- Using the floodlight to dazzle people or interfere with shipping traffic.
- Using the floodlight as a handle.
- Hanging objects from the cable or holding on to the cable.

## 4. Operation

The floodlight is exclusively operated using the light switch installed on-site in the electrical supply line.

If the product is not to be used for longer, no preparation is required.  
A visual inspection before recommissioning is recommended.

## 5. Malfunctions during operation

Repairs and maintenance must only be performed by skilled personnel with proven qualifications.

In case of malfunctions, first consider the measures listed below:

Problem	Cause	Remedy
Light cannot be switched on	Power supply is interrupted	Re-establish the power supply: Switch/ connection.
	Light switch is defective	Ask the electrician to replace the light switch.
	Module is defective	Ask the electrician to replace the LED module.
	Fuse failed/is short	Eliminate the error and then switch on the fuse.
	Floodlight is incorrectly connected	Ask the electrician to check the connection.
	Connection cable is defective	Ask the electrician to replace the connection cable or LED module.
	Incorrectly installed cables	Ask the electrician to change the installation
Water in the LED module	Ventilation is defective	Ask the electrician to replace the LED module.
	Housing is broken	
	Washer is leaking	
Incorrect illumination	Floodlight suspension needs adjusting	Realign the floodlight and retighten the screws.
One LED module does not work	LED module is defective	Ask the electrician to replace the LED module. Individual LEDs cannot be exchanged.
Light flickers	A dimmer is connected	Ask the electrician to remove the dimmer.
	Malfunction in the electrical system	Inform the electrician.

## 6. Cleaning

Clean the outer surfaces of the floodlight with a soft, dry cloth. In case of heavy soiling, slightly moisten the cloth with clear water.



### WARNING

Risk of electric shock!

➔ Before cleaning, switch off the floodlight / disconnect it from voltage sources.

### ATTENTION

Do not use solvents, petrol, or alcohol while cleaning. Further, do not use sharp-edged tools, screwdrivers, metal brushes, or the like. They can damage the surfaces of the floodlight.

## 7. Regular review

The floodlight is maintenance-free. In case of problems or malfunctions, please refer to the chapters “Troubleshooting” and “Maintenance.”

Perform visual and functional tests at regular intervals—at least once a month.

The examination should include the following:

- A visual inspection for damage and heavy soiling of the case.
- A visual inspection for damage or rust on the retaining bracket and fixing screws.
- A visual inspection for damage to the cables.
- A visual inspection for damage and contamination to the protective glass.
- A visual inspection for the formation of condensed water in the LED module.
- A function test of the light source.
- A function test of the retaining bracket.
- A test for noises (crackling, humming) and heated supply lines.



### WARNING

Danger of glare!

The light intensity can permanently damage the eyes if the floodlight is switched on during maintenance work. People can become disoriented and fall down.

- Before maintenance, switch off the light and secure the product from being switched on again.

## 8. Disposal and decommissioning

Comply with the local and national laws, guidelines, and regulations regarding the disposal of materials and products.

**Waste Electrical and Electronic Equipment** (applicable in the European Union and other European countries with separate collection systems.)

The electrical appliances by WISKA Hoppmann GmbH are professional electrical appliances, which are also called business-to-business (B2B) appliances. We take back old electrical appliances in accordance with the national WEEE law (i.e., in Germany § 19 ElektroG) and dispose of them properly. Please contact us before shipping your old WISKA electrical appliances at [contact@wiska.de](mailto:contact@wiska.de). Components, such as cable glands, do not fall under this law.

Do not mix or dispose of old electrical equipment from WISKA Hoppmann GmbH with other commercial waste.

## 9. Transport and storage

Transport and storage only permitted in original packaging.

## 10. Mounting and electrical connection

Installation, commissioning, maintenance, and repair should exclusively be carried out by skilled personnel with proven qualifications.



### DANGER



Danger to life from electric currents



Working on open circuits can result in short circuits and body shorts.



- An electrician should be present when working on electrical components.
- Make sure that the system is disconnected from the electrical connection.
- Secure the power supply against being switched on again.
- Cover open external plant components.
- If necessary, short-circuit the system components.
- Test whether the system is voltage-free.

### 10.1 Preparation

Required tools	Screwdriver, open-end wrench, ratchet		
<b>1</b>	Mark the mounting position.		
<p><b>ATTENTION:</b> Malfunctions due to constantly dripping water are possible. Do not install floodlights under drip edges or rain gutters. Maintain a minimum distance of 30 cm from a drip edge.</p>			
<b>2</b>	Prepare mounting points for onboard installation.		
		<p><b>Version</b> 5000 1x40</p>	<p><b>L1 = 300mm</b> <b>L2 = 250mm*</b> <b>L3 = 160 mm</b></p>
		<p><b>Version</b> 5000 2x40 5000 3x40</p>	<p><b>L1 = 300 mm</b> <b>L2 = 160 mm</b> <b>L3 = 70 mm</b></p> <p><b>B = 434mm</b></p>
		<p><b>Version</b> 5000 4x40</p>	<p><b>L1 = 309 mm</b> <b>L2 = 249 mm</b> <b>H1 = 60 mm</b> <b>H2 = 35 mm</b></p> <p><b>B = 437mm</b></p>

\*use only together with a mobile railing bracket.

## 10.2 Mounting

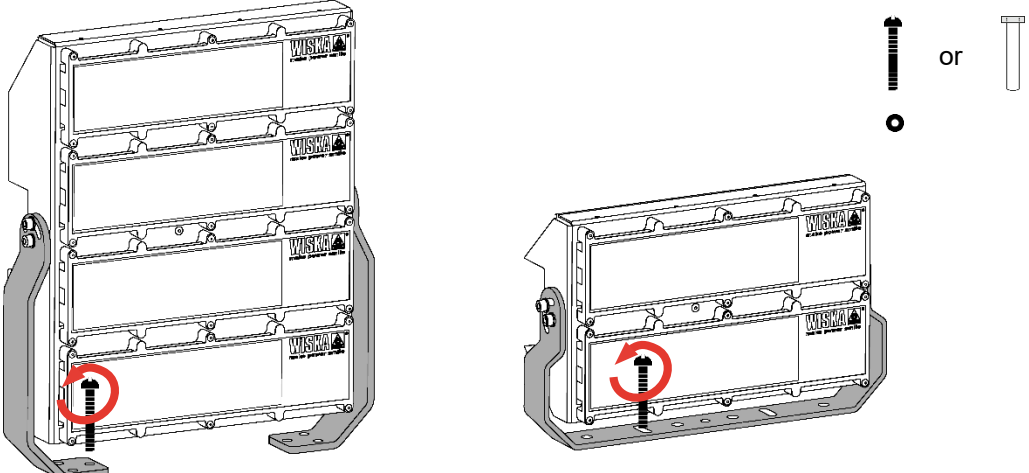
Required tools	Screwdriver, open-end wrench, ratchet lever
<b>3</b> Fix the floodlight with screws or bolts to the wall or to the ceiling	
	

## 10.3 Electrical Connection

See 13.5 Electrical diagram for specifications

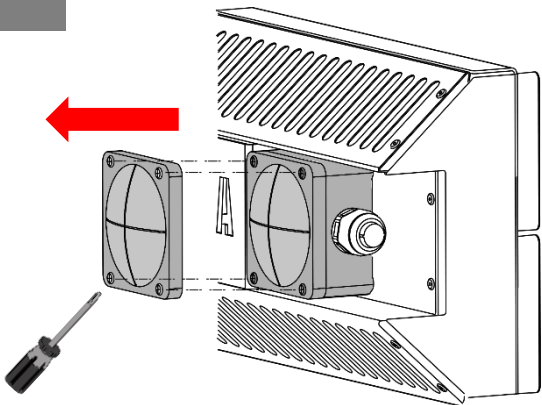
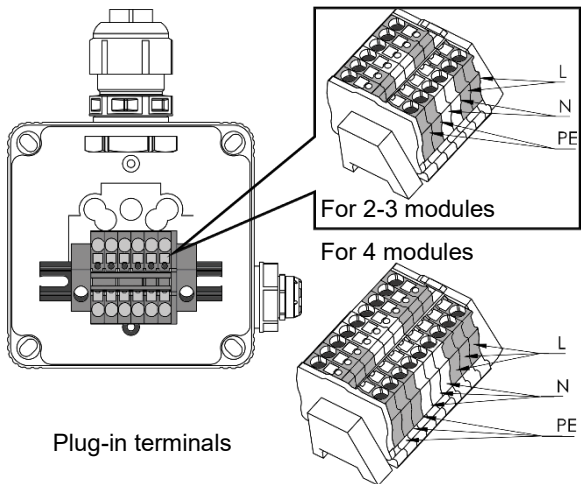
Required tools	Screwdriver, open-end wrench, ratchet lever
<b>4</b> Open the terminal box.	
	<b>5</b> Terminal box open. Terminal blocks with push-in connectors.
	
<b>i</b> The tightening torque for the cable gland should be <b>4Nm!</b>	

Connection of the 100 to 240 VAC models:

**6a** 100 to 240 VAC: Wire it up.  
Use Phase (L), Neutral (N), and Protective Earth (PE) conductors.

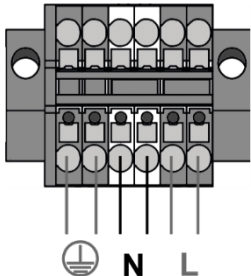

Brown = L  
Blue = N  
Yellow/green = PE

Hint:  
The single module version comes without junction box/ terminal

Alternatively, connection of the 24 VDC models:

**6b** 24V: Check the filter is installed in the junction box.  
Wire the floodlight up.

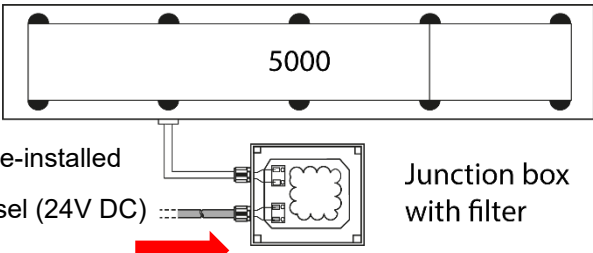

1.5m cable pre-installed  
From the vessel (24V DC)

Junction box with filter

Brown = (+) Positive, Blue = (-) Negative

Finish the connection:

**7** Lay on the wires.  
Insert the cores

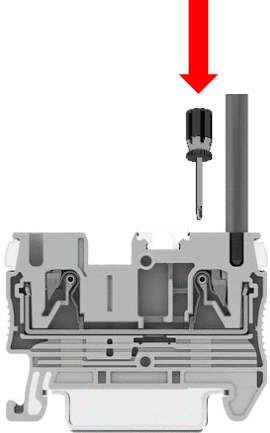

**8** Close the terminal box.  
Close the cover screws.

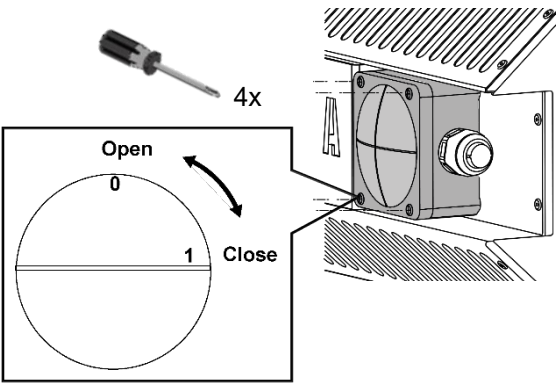

**9** ✓

## 11. Commissioning

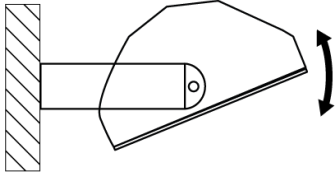
Required tools	Screwdriver
<p><b>1</b> Align the floodlight with the surface to be illuminated.</p>	
<p><b>2</b> Firmly tighten the screws.</p>	<p><b>i</b> Tightening torque for: floodlight with one module, <b>10Nm</b>, floodlight with several modules, <b>25Nm</b>.</p>
<p><b>3</b> Check the floodlight's functioning.</p>	<p><b>4</b> ✓</p>

## 12. Maintenance and repair

### **DANGER**



Danger to life from electric currents.

Working on open circuits can lead to short circuits and body short circuits.



- An electrician should be present when working on electrical components.



- Make sure that the system is disconnected from the electrical connection.
- Secure the power supply against being switched on again.
- Cover open external plant components.
- If necessary, short-circuit the system components.
- Test whether the system is voltage-free.

### 12.1 Replacement of the module (floodlights with one module)



Replacement of the module for the one-module floodlight version.



**DANGER** of electric shock.

Disconnect the floodlight from the power supply.

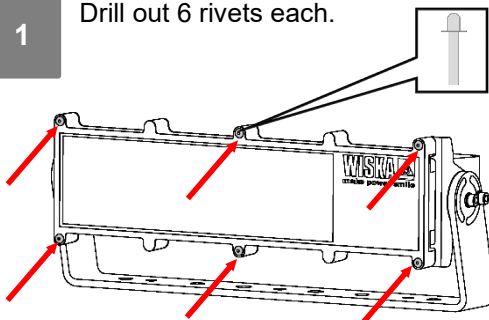
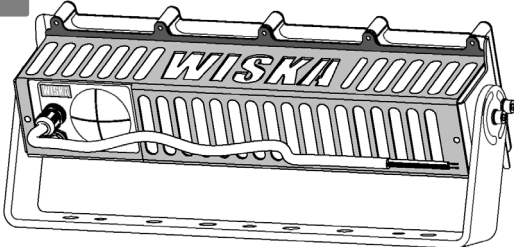
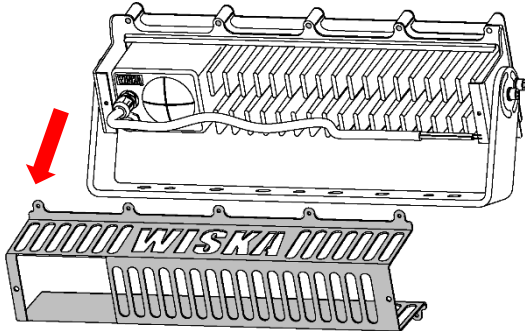
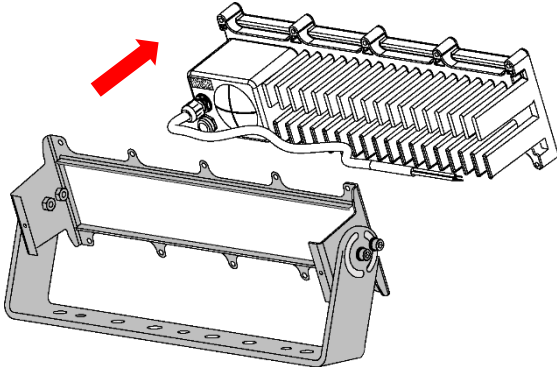
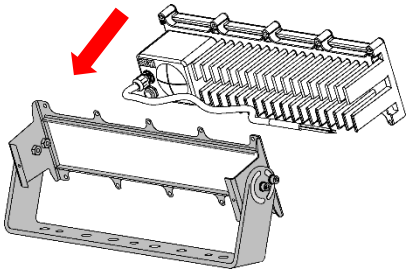
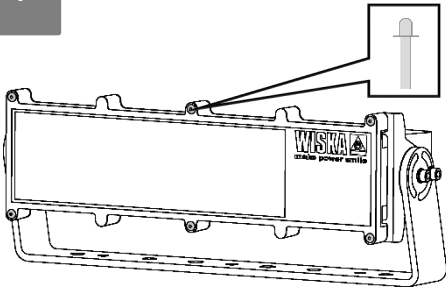
Observe safety measures to prevent reconnection.

<p>Required tools</p>	<p>Screwdrivers (reuse the screws.)</p>
<p><b>Caution</b> Switch off the floodlight and disconnect the connection cable before starting the maintenance process.</p>	
<p><b>1</b> Drill out 6 rivets each.</p> 	<p><b>2</b> Loosen the rear cover.</p> 
<p><b>3</b> Remove cover.</p> 	<p><b>4</b> Lift the old module out of the frame.</p> 
<p><b>5</b> Insert the new module.</p> 	<p><b>6</b> Assemble the parts.</p> <p>Replace the cover.</p>
<p><b>7</b> Attach 6 rivets at original positions.</p> 	<p><b>8</b></p> 



## 12.2 Replacement of a module (floodlights with multiple modules)

Identical process for replacing a module for the 5000 2x40, 5000 3x40, and 5000 4x40 versions.

**⚠ DANGER** of electric shock

Disconnect the floodlight from the power supply.

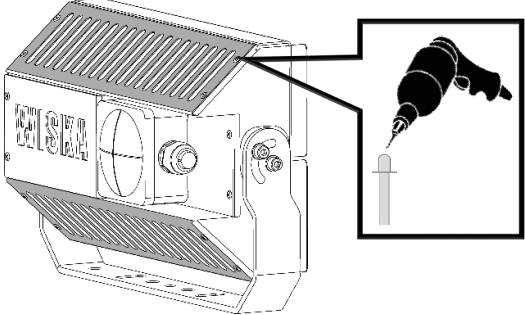
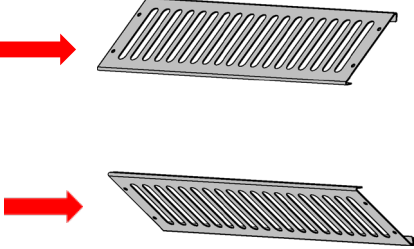
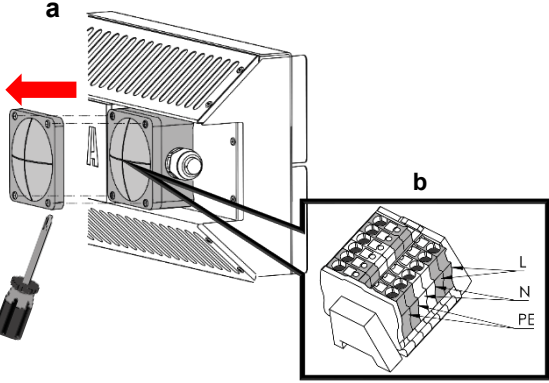
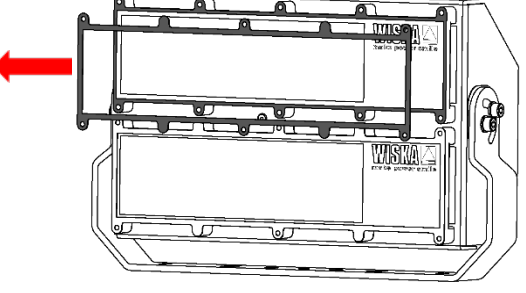
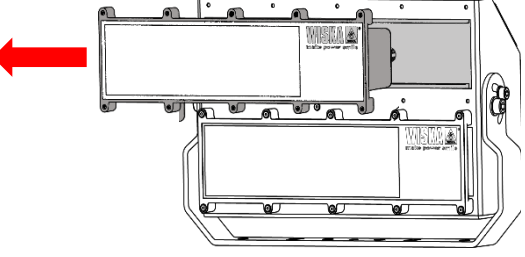
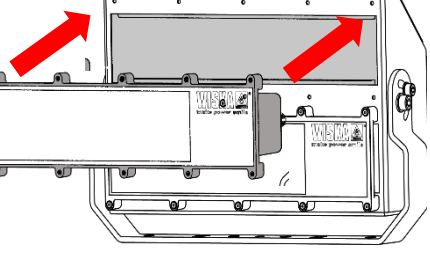
Observe safety measures to prevent reconnection.

Required tools	Electric drill, rivets, screwdriver
<p><b>1</b> Drill out 4 rivets each to loosen the rear cover above and below the terminal box.</p> 	<p><b>2</b> Remove the cover to loosen the cable gland.</p> 
<p><b>3</b> Open the terminal box (a). Disconnect the wires (b).</p> 	<p><b>4</b> Remove the front rivets. Remove the module frame.</p> 
<p><b>5</b> Pull the module out of the frame.</p> 	<p><b>6</b> Insert the new module.</p> 
<p><b>7</b> Assembling and riveting in reverse order.</p> 	<p><b>8</b></p> 

### 12.3 Mounting the protective grid (optional)

#### Mounting on a single-module floodlight

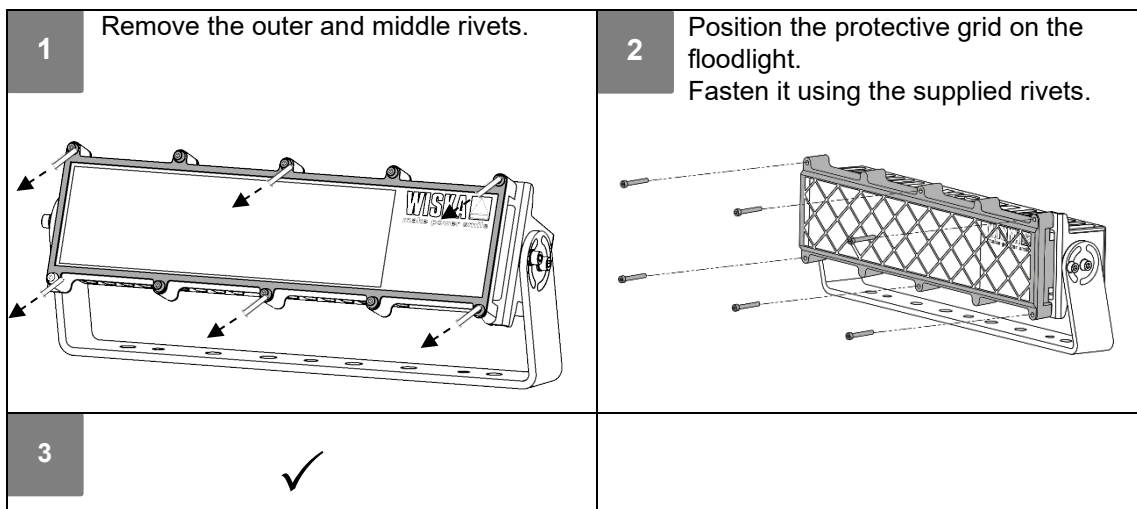

#### Mounting on a floodlight with multiple modules

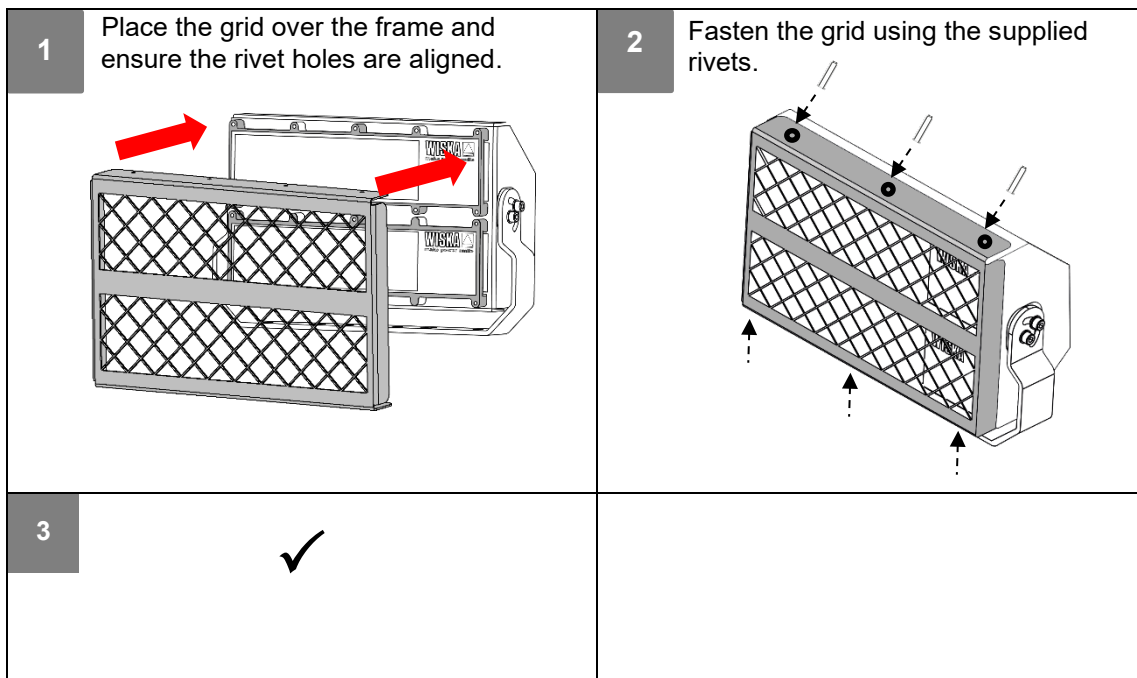

## 13. Technical data

Specification	MB	NL	WB
<b>Illuminant type</b>	LED		
<b>Operating voltage</b>	100 to 240 VAC or 24VDC		
<b>Luminous flux</b>	At least 4000 lm per module		
<b>Light color</b>	5600 K		
<b>Power per Module</b>	approx. 40 W		
<b>Rated lifetime</b>	L70/B10 @Ta +45° C		
<b>System Lifetime</b>	120000 h		
<b>Lens</b>	Medium beam	Narrow beam	Wide beam
<b>Material</b>	High-performance plastic / powder-coated stainless steel		
<b>Cable gland</b>	2x M20 or 1x M25 (only for floodlights with 2–4 modules)		
<b>Colour</b>	Black/white		
<b>Degree of protection</b>	One module: IP66/68 Multiple modules: IP66/67		
<b>Protection class</b>	SK I/protective conductor		

### 13.1 Dimensions (mm)

Version	Outer dimensions*			Mounting bracket			Weight**
	W	H	D	L	W	H	
	mm	mm	mm	mm	mm	mm	kg
5000 – 1×40	405	155	115	405	50	120	4.3
5000 – 2×40	434	269	148	434	50	185	9.2
5000 – 3×40	434	397	148	434	50	185	12.5
5000 – 4×40	437	509	148	437	60	305	16.4

\* Including the mounting bracket

\*\* Without the protective grid

Version	Outer dimensions*			Mounting bracket			Weight**
	W	H	D	L	W	H	
	inch	inch	inch	inch	inch	inch	lb
5000 – 1×40	15.9	61	45.3	159.4	19.7	47.2	9.48
5000 – 2×40	17.1	105.9	58.3	17.1	19.7	72.8	20.28
5000 – 3×40	17.1	156.3	58.3	17.1	19.7	72.8	27.56
5000 – 4×40	17.2	200.3	158.3	17.2	23.6	120	36.16

### 13.2 Dimensional drawings

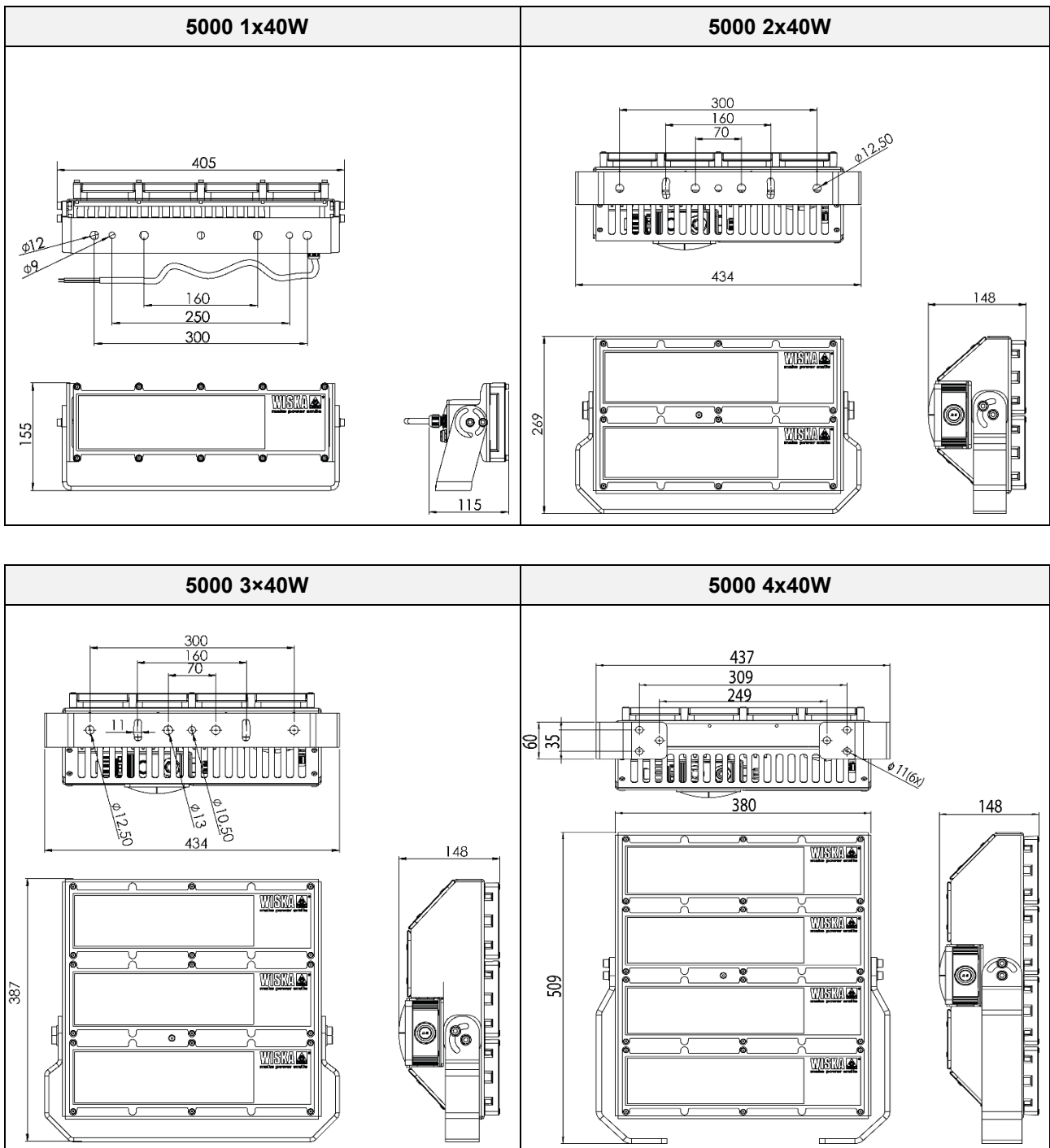

### 13.3 Product identification

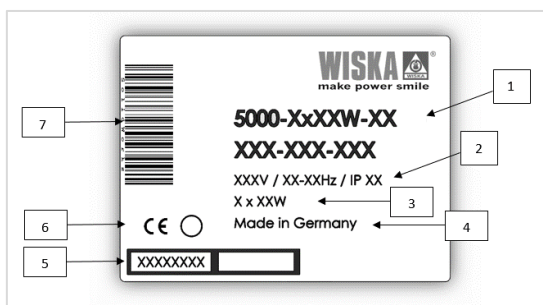

Illustration for the Floodlight 5000 nameplate.

The type label has a three-row design and includes the following:

Pos.	Designation
1	Article short text
2	Performance data
3	Power consumption
4	Country of origin
5	Serial number
6	Notified Body
7	Identification index

### 13.4 Scope of delivery

The floodlight is mainly custom-made.

It optionally features a narrow, medium, or wide beam lens and a protective grid.

Further options are available based on the order.

**Note:** A connection cable is only provided with Floodlight 5000 1×40.

### 13.5 Electrical diagram

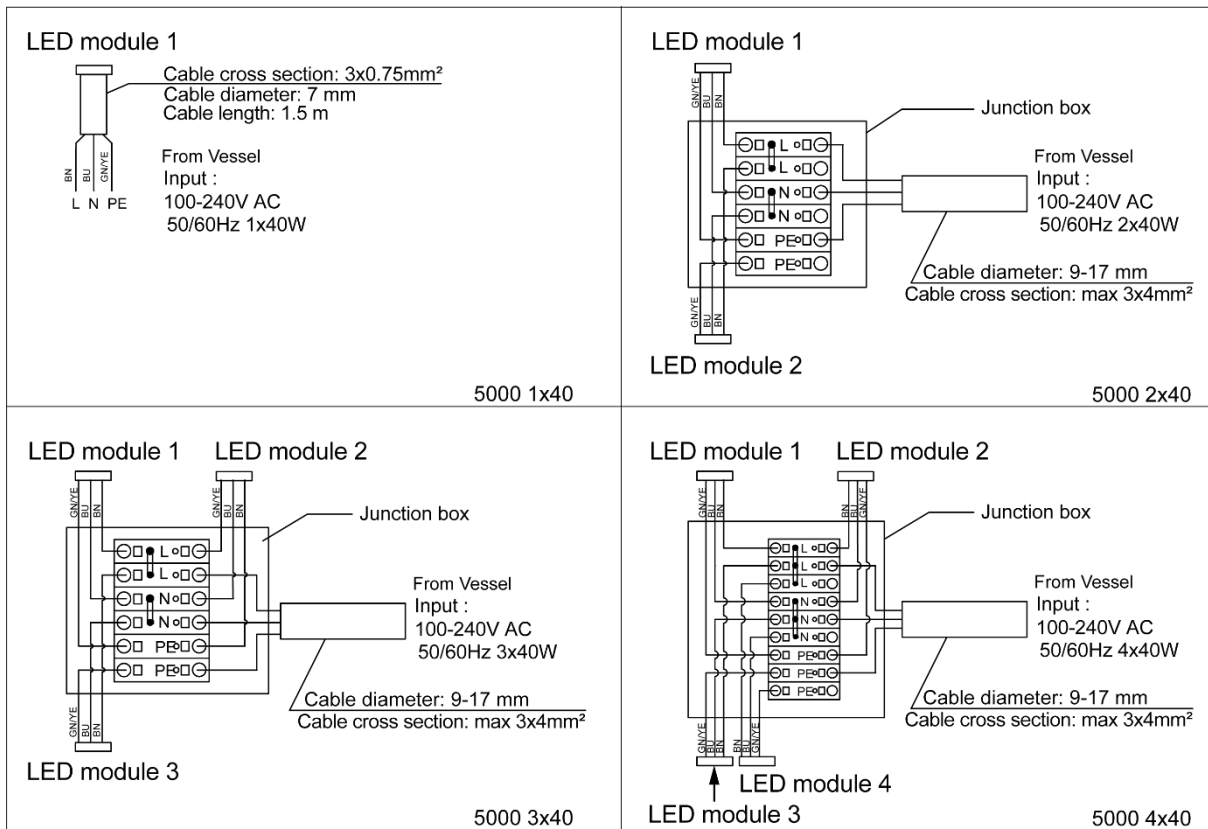

L-Cable: brown (BN)  
 N-Cable: blue (BU)  
 PE-Cable: green/yellow (GN/YE)

L-Terminal in connection box: grey (GY)  
 N-Terminal in connection box: blue (BU)  
 PE-Terminal in connection box: green/yellow (GN/YE)

Model 5000-1x 40-24-MB-FN-1CC with separately enclosed junction box COMBI 607.

It is mandatory to install the filter to ensure the EMC characteristics.

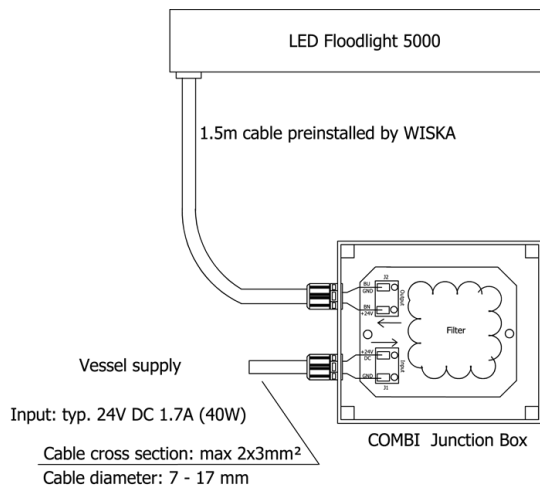

## 14. Accessories/spare parts

Use only original WISKA accessories and spare parts. Accessories and spare parts (e.g. cable glands, pressure compensation plugs, seals). They can be obtained from WISKA Service.

### Spare parts

No.	Designation	Article no.
1	LED Light Module, AC, with 0.35 m cable*	
	SP-5000 LED Light Engine MB, 0.35 m	22000965
	SP-5000 LED Light Engine NB, 0.35 m	22001205
	SP-5000 LED Light Engine WB, 0.35 m	22001206
2	LED Light Module with 1.5 m cable	
	SP-5000 LED Light Engine MB, 1.5 m (AC)	22001008
	SP-5000 LED Light Engine NB, 1.5 m (AC)	22001207
	SP-5000 LED Light Engine WB, 1.5 m (AC)	22001208
	SP-5000 LED Light Engine 24V DC MB, 1.5 M	22001263
3	Mounting bracket	
3.1	Mounting bracket, for the single variant	22000984
3.2	Mounting bracket, for the double/ triple variants	22000998
3.3	Mounting bracket, for the fourfold variant	22000985
4	Cover	
4.1	Cover, for the single variant	22000991
4.2	Cover, for the multiple variants	22001131
5	Junction box	
5.1	Junction box for the double variant	22000995
5.2	Junction box for the triple variant	22000996
5.3	Junction box for the fourfold variant	22000997
6	Protective grids	
6.1	Protective grid for the single variant	22000986
6.2	Protective grid for the double variant	22000988
6.3	Protective grid for the triple variant	22000989
6.4	Protective grid for the fourfold variant	22000990

\* MB (medium beam), NB (narrow beam), WB (wide beam)

## 15. Declaration of Conformity/Certificate

The declaration of conformity for each floodlight can be found on [www.wiska.com](http://www.wiska.com).



WISKA Hoppmann GmbH  
 Kisdorfer Weg 28  
 24568 Kaltenkirchen  
 Germany



KCE3-21001-1

Declares under its sole responsibility that:

<b>Product designation:</b>	Floodlight
<b>Type designation::</b>	5000/*x40W/**/*/**/*/**/*
<b>Description:</b>	Floodlight for electrical installation

corresponds to all the relevant provisions of the directives listed below and valid harmonized and / or international and national standards - including all applicable changes at this time of issuing this document.

Regulation	Standard
2014/35/EU Electrical apparatus (Low voltage directive)	EN 60598-1:2015 + A1:2018
	EN 60598-2-5:2015
	EN IEC 62031:2020
	EN 61000-4-2:2009
	EN 61000-4-3:2006 + A1:2008 + A2:2010
2014/30/EU Electromagnetic compatibility (EMC)	EN 61000-4-4:2012
	EN 61000-4-5:2014 + A1:2017; Corrigendum 1
	EN 61000-4-6:2014
	EN IEC 55015:2019 + A11:2020
	Other Standards

WISKA Hoppmann GmbH  
 Kaltenkirchen, Germany

Head of Engineering & Design

2023-02-21

# DECLARATION OF CONFORMITY



WISKA Hoppmann GmbH  
 Kisdorfer Weg 28  
 24568 Kaltenkirchen  
 Germany

Authorised Representative:  
 WISKA UK Ltd.  
 Unit 7, Hurling Way  
 St. Columb Major Business Park  
 St. Columb Major, Cornwall  
 TR9 6SX  
 GREAT BRITAIN



KGB3-21001-1

Declares under its sole responsibility that:

Product designation:	Floodlight
Type designation:	5000/*x40W/**/*/**/*/**/*/**/*
Description:	Floodlight for electrical installation

corresponds to all the relevant provisions of the directives listed below and valid harmonized and / or international and national standards - including all applicable changes at this time of issuing this document.

Regulation	Standard
SI 2016 No. 1101 The Electrical Equipment (Safety) Regulations 2016	EN 60598-1:2015 + A1:2018
	EN 60598-2-5:2015
	EN IEC 62031:2020
	EN 61000-4-2:2009
	EN 61000-4-3:2006 + A1:2008 + A2:2010
SI 2016 No. 1091 The Electromagnetic Compatibility Regulations 2016	EN 61000-4-4:2012
	EN 61000-4-5:2014 + A1:2017; Corrigendum 1
	EN 61000-4-6:2014
	EN IEC 55015:2019 + A11:2020
	Other Standards

WISKA Hoppmann GmbH  
 Kaltenkirchen, Germany

WISKA UK Ltd  
 St. Columb Major, Great Britain

2023-01-26

Head of Engineering & Design

Authorised Representative





## TYPE APPROVAL CERTIFICATE

Certificate No:  
**TAE0002AB**  
Revision No:  
**4**

### This is to certify:

**That the Light Fitting**

with type designation(s)  
**LED Floodlight 5000**

Issued to

**WISKA Hoppmann GmbH**  
**Kaltenkirchen, Germany**

is found to comply with

**DNV rules for classification – Ships, offshore units, and high speed and light craft**

### Application :

**Product(s) approved by this certificate is/are accepted for installation on all vessels classed by DNV.**

<b>Vibration class</b>	<b>A</b>
<b>Degree of protection</b>	<b>IP 66/67</b>
<b>Temp. class</b>	<b>D</b>
<b>Voltage (V)</b>	<b>100-240V AC, 24V DC</b>
<b>Suitable for Hazardous areas</b>	<b>No</b>

Issued at **Høvik** on **2022-10-12**

This Certificate is valid until **2027-10-11**.

DNV local station: **Hamburg**

Approval Engineer: **Maik Gagern**



for **DNV**

Digitally Signed By: **Alonso Pontes, Marta**  
Location: **DNV Høvik**

**Marta Alonso Pontes**  
**Head of Section**

This Certificate is subject to terms and conditions overleaf. Any significant change in design or construction may render this Certificate invalid. The validity date relates to the Type Approval Certificate and not to the approval of equipment/systems installed.

LEGAL DISCLAIMER: Unless otherwise stated in the applicable contract with the holder of this document, or following from mandatory law, the liability of DNV AS, its parent companies and their subsidiaries as well as their officers, directors and employees ("DNV") arising from or in connection with the services rendered for the purpose of the issuance of this document or reliance thereon, whether in contract or in tort (including negligence), shall be limited to direct losses and under any circumstance be limited to 300,000 USD.



Form code: TA 251

Revision: 2021-03

www.dnv.com

Page 1 of 3

**WISKA Hoppmann GmbH**  
Kisdorfer Weg 28  
24568 Kaltenkirchen  
Germany

Phone +49 (0) 4191 508-0  
Fax +49 (0) 4191 508-249

[contact@wiska.de](mailto:contact@wiska.de)  
[www.wiska.com](http://www.wiska.com)

ORIGINAL  
Subject to change without notice!

01/2023